



## CONSUMER BENEFITS



### Comfortable Handling

Handles make it possible to carry up to two containers at the same time.



### Integrated Soft And Self-Closing

Damping mechanism for smooth and silent closing.



### Gentle For The Laundry

Gentle on delicate laundry thanks to rounded edges, which also ensure the best possible air circulation.



### Various Bin Sizes

The right height and width for every cabinet.

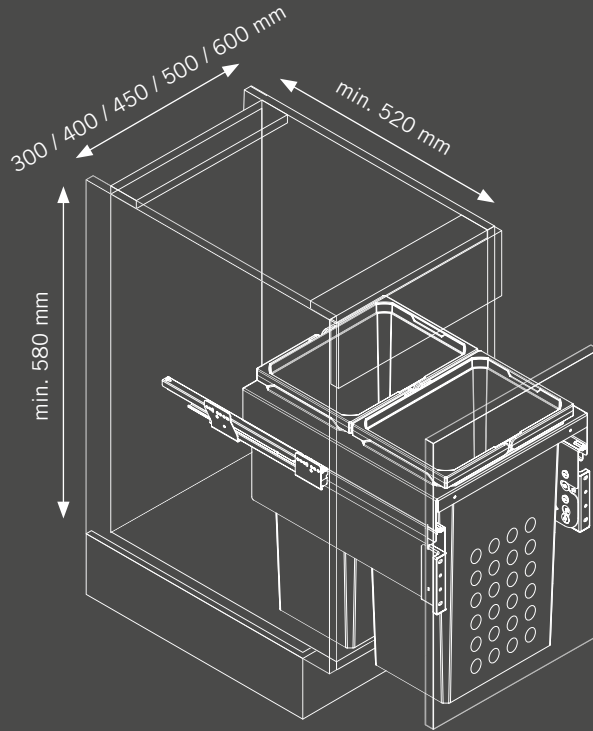

## INSTALLER BENEFITS



### One System

The same system for recycling and laundry. Tailored bins are available for each of these uses.



### Tool-Free Assembly Of The System On The Runners

No tools needed when assembling the system on the runners.



### Installation Template

No measuring necessary.



### 3D Cam Shaft Adjustment

Allows simple, convenient front adjustment, even after installing into the cabinet.



### Retrofit Ready

Can be installed in existing cabinetry without removing the countertop.