

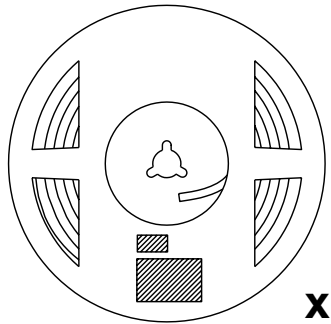

24V₌₌
10W/m
(EDC)
3000 - 4000K

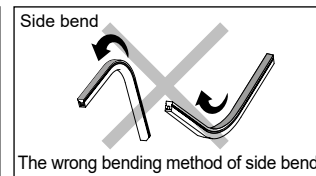

VERSION (L=mm)
 1000mm
 2000mm
 3000mm
 6000mm (fig.4)

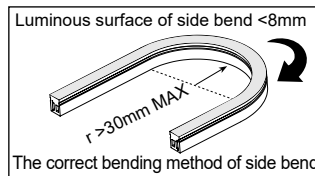
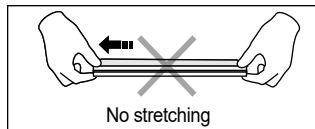
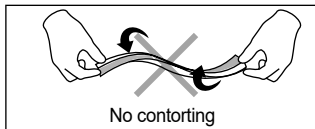
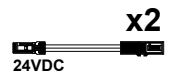
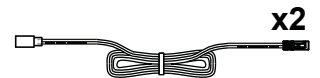
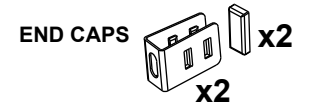
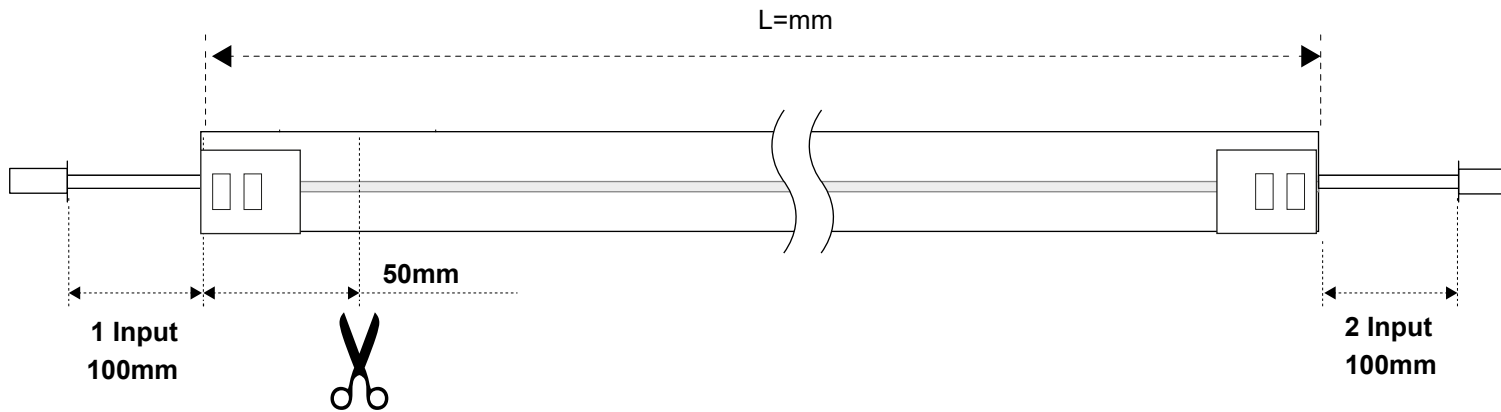
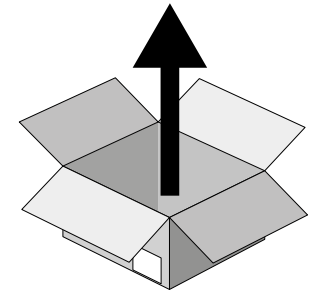
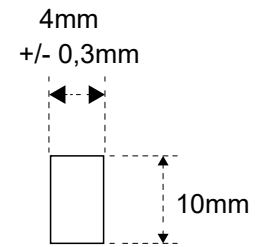

CUTTING KIT

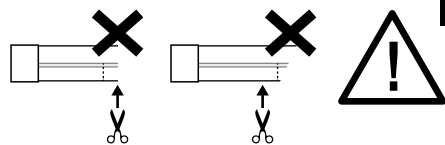

1

Dimensione Fresata
Drill Dimension
Ausmaß der fräsarbeit
Medida del corte
Mesures fraise

$$4,3 \leq \text{width (mm)} \leq 4,5$$

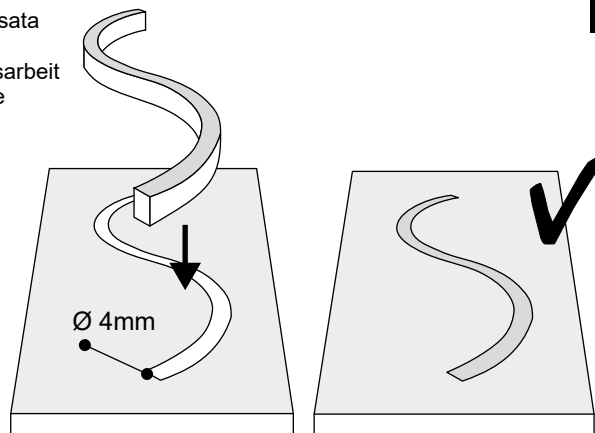
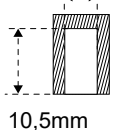

2

FIXING CLIPS

VENDUTO A PARTE
SOLD SEPARATELY
SEPARAT VERKAUFT
VENDE APARTE
VENDU À PART

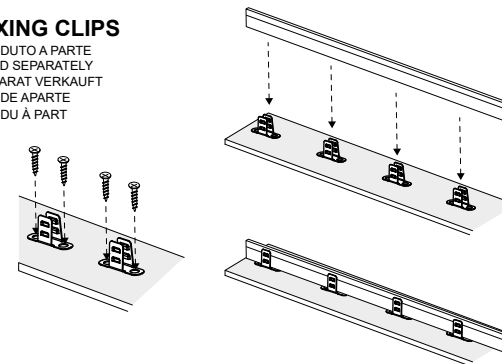

3

FIXING CLIPS

VENDUTO A PARTE
SOLD SEPARATELY
SEPARAT VERKAUFT
VENDE APARTE
VENDU À PART

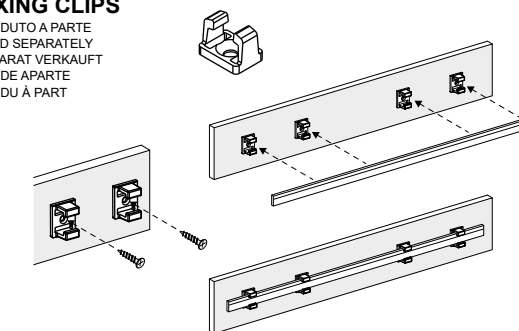

* assicurarsi che la superficie sia idonea al montaggio / make sure that the surface is suitable for mounting / stellen Sie sicher, dass die Oberfläche für die Montage geeignet ist / asegúrese de que la superficie es adecuada para el montaje / assurez-vous que la surface est adapté pour le montage

VERSION (L=mm)

1000mm
2000mm
3000mm

A

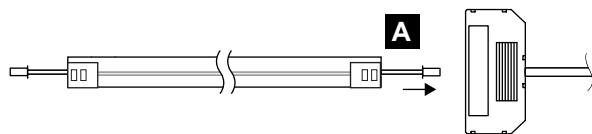

6000mm
(>4000mm)

A + B

MANDATORY

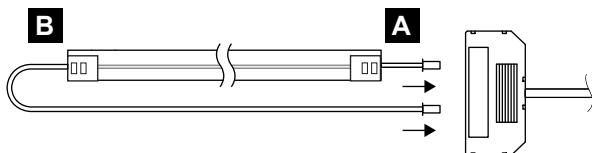

4

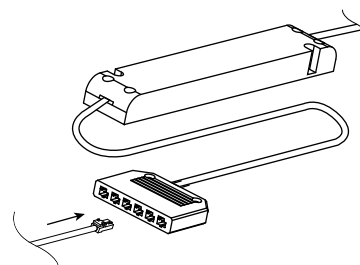

OPTION

EMOTION JUMPER

4a

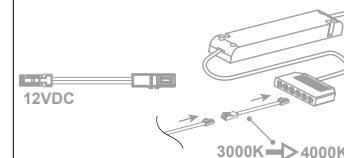

EXTERNAL CONTROLLER

4b

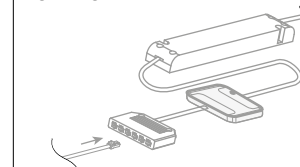

5

